

INCH-POUND

MS20001P
 21 May 2012
 SUPERSEDING
 MS20001N
 16 November 2010

DETAIL SPECIFICATION SHEET

HINGE, BUTT STRUCTURAL, EXTRUDED

This specification sheet is approved for use by all Departments and Agencies of the Department of Defense.

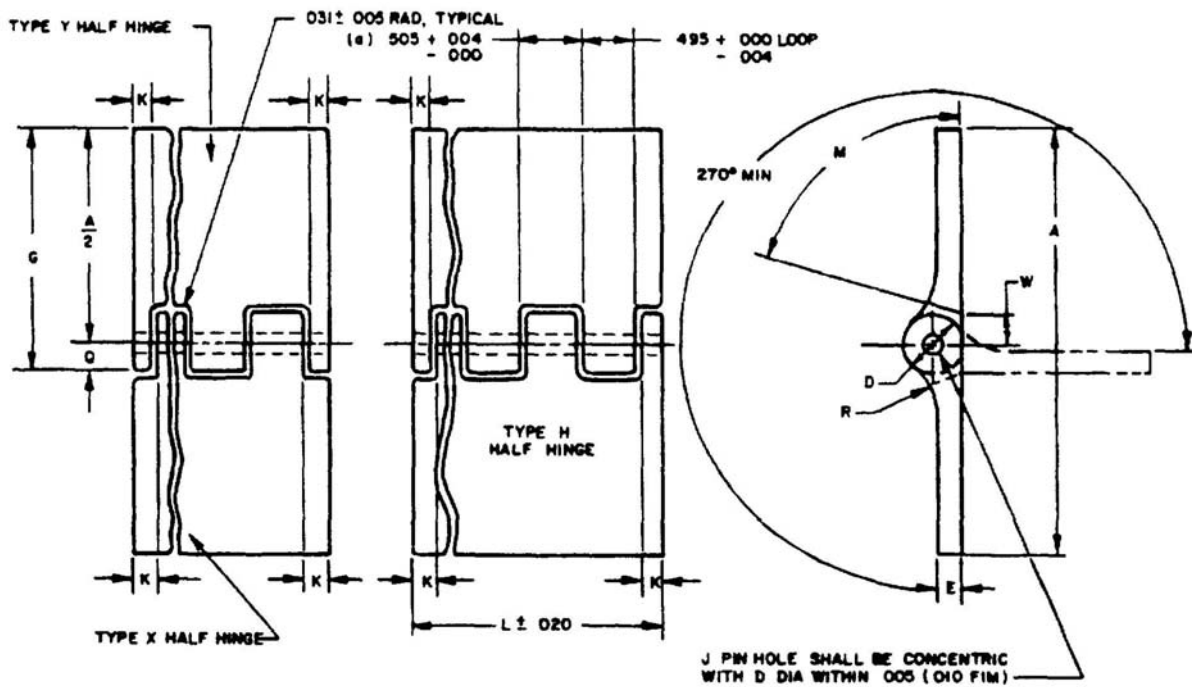

FIGURE 1. Butt hinge.

MS20001P

TABLE I. Dimensions.

Dash no.	A Ref Width Open	E		G		Q $\pm.005$	J Dia $+.005$ $-.000$	(b) K Min	D dia		R $\pm.031$ Rad	W $\pm.016$	Pin dia. ref.	M $\pm 2^\circ$
		Max	Min	Max	Min				Max	Min				
-2	1.062	.056	.044	.630	.612	.090	.093	.188	.187	.173	.174	.135	.090	75°
-3	1.250			.724	.706									
-4	1.500			.850	.830									
-5	1.750			.975	.955									
-6	2.000			1.102	1.078									
-8	2.000	.076	.064	1.167	1.143	.155	.183		.318	.302	.297	.200	.180	
-9	2.500	.056	.044	1.352	1.328	.090	.093		.187	.173	.174	.135	.090	
-10	2.750			1.477	1.453				.320	.304	.375	.188		
-12	3.375	.115	.103	1.860	1.828	.156			.414	.398	.625	.240	.130	60°
-14	3.719	.163	.149	2.086	2.038	.203	.133		.509	.491	.750	.287	.180	45°
-16	3.938	.210	.196	2.243	2.195	.250	.183							

(a) Tolerances for dimensions on pitch shall not be cumulative.

(b) Dimension K must never exceed a full loop or tang, and both ends must be equal within .020 inch.

INTERCHANGEABILITY RELATIONSHIP, see table II. MS20001 hinges are not universally interchangeable with AN252 hinges.

TABLE II. Interchangeability.

Inactive and cancelled	Universally interchangeable
AN252-1	-----
AN252-2	MS20001-2
AN252-4	MS20001-4
AN252-6	MS20001-6
AN252-8	MS20001-8
AN252-10	MS20001-10

MS20001P

REQUIREMENTS:

1. Material Aluminum alloy 2024-T3511 per SAE-AMS-QQ-A-200/3, ASTM-B221, ASTM-B241/B241M or aluminum 7075-T73511 per SAE-AMS-QQ-A-200/11, ASTM-B241/B241M, ASTM-B221 (see note 6).
2. Finish Anodize in accordance with MIL-A-8625, Type II, chemical surface treat in accordance with MIL-DTL-5541 (ends of all hinges shall be finished).
3. Marking Ink stamp MS20001 (dash number) at regular intervals along length of hinge so that any three inch length will have at least one complete identification in figures not less than 0.060 inch high (see note 5).
4. Complete hinges shall be furnished as an assembly with CRES hinge pins of the same length in accordance with SAE-AS20253 (see note 6).
5. Designation for anodizing, chemical surface treatment, hinge style and hinge length shall not be included in the marking. Suppliers to end users shall attach tags to the hinges with the complete part number (see Note 7), which shall match the complete part number on the hinge packaging.
6. Only complete hinges to be stocked by services.
7. Use MS20257 hinge whenever load requirements permit.

NOTES:

1. Dimensions are in inches.
2. Remove all burrs and sharp edges.
3. Type X half hinge mates with type Y half hinge, as shown.
4. Type H half hinge mates with type H half hinge.
5. For service procurement, the preferred stock length of complete hinges is 72 inches.
6. Part numbering (nomenclature to be included on shipping documents only). Part numbering shall consist of the following (in sequence):

MS20001P

- a. MS20001
 - b. “P” for anodized finish, “C” for chemical surface treatment, omission of code letter will indicate bare finish.
 - c. “H”, “X”, or “Y” to designate half hinge style, omission of code letter will indicate complete hinge.
 - d. “A” for 7075-T73511 aluminum alloy hinge, omission of “A” will indicate 2024-T3511 aluminum alloy.
 - e. Dash number (table I), omit dash if preceded by code letter.
 - f. A dash followed by length “L” expressed in inches and hundredths.
7. Examples of part numbers:
- MS20001-4-1200 - Complete hinge, bare finish, aluminum 2024-T3511, CRES hinge pin, 1.500 inches wide, 12.00 inches long.
- MS20001CHA4-900 - Type H half hinge, chemical surface treatment, aluminum 7075-T3511, 1.500 inches wide, 9.00 inches long.
8. Do not specify “P” for anodize if hinge is to be spot welded.
 9. Referenced documents shall be of the issue in effect on date of invitation for bids, or request for proposal except that referenced adopted industry documents shall give the date of the issue adopted.
 10. For design feature purposes, this standard takes precedence over procurement documents referenced herein.

Changes from previous issue: The margins of this specification are marked with vertical lines to indicate where changes from the previous issue were made. This was done as a convenience only and the Government assumes no liability whatsoever for any inaccuracies in these notations. Bidders and contractors are cautioned to evaluate the requirements of this document based on the entire content irrespective of the marginal notations and relationship to the last previous issue.

MS20001P

CONCLUDING MATERIAL

Custodians:

Army - AV
Navy - AS
Air Force - 99

Preparing activity:

Navy - AS
(Project 5340-2012-008)

Review activity:

DLA - IS

NOTE: The activities listed above were interested in this document as of the date of this document. Since organizations and responsibilities can change, you should verify the currency of the information above using the ASSIST Online database at <https://assist.dla.mil>.